

**X** *GYRO REMOTE CONTROL SERIES 2.4G*  
**54HC-X54HW**   
**4CH 2.4G REMOTE CONTROL QUADCOPTER**

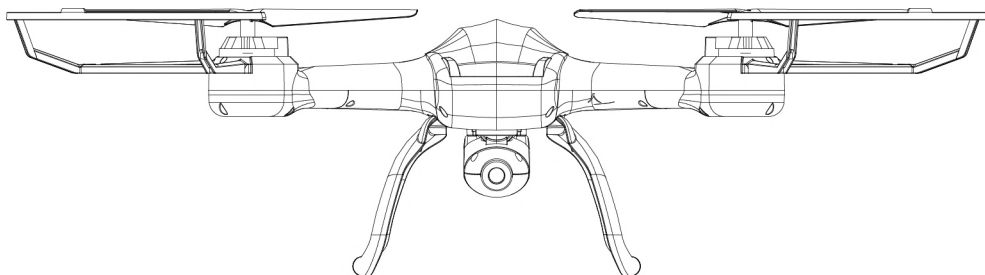

# INSTRUCTIONS

## *Highlights:*

- Brand new altitude-hold mode makes operation easier. Simply pair the quadcopter with the remote control, engage the throttle and the quadcopter will stay at the same altitude. The quadcopter also features a high-resolution on-board camera for better quality images and video.
- Better designed structure makes the quadcopter more flexible and faster. The wind-resistance feature allows to flight stability and suitable for indoor & outdoor flight.
- 6 axis gyroscope for precise hovering in the sky.
- Simple design makes the parts replacing easy.
- Easy to disassemble and packed with a whole range of features, such as flip manoeuvres and an on-board camera.

The materials, specifications and components stated or illustrated in these instructions are for reference purposes only. We shall not be responsible for any changes to this publication, nor are we able to inform customers of any updates or changes.

# SAFTY&CAUTIONS

1. Please keep small parts out of the reach of children to prevent the risk of an accident
2. The quadcopter is very powerful, therefore engage the throttle slowly when you fly it for the first time in order to prevent it from ascending too rapidly, which could damage the quadcopter due to a collision.
3. When you have finished using the quadcopter, turn off the remote control and then switch off the quadcopter.
4. Do not expose batteries to heat or high temperatures (such as naked flames or near to electric heaters).
5. Make sure that the quadcopter is kept at a distance of 2-3 m from the pilot or other people to ensure that the quadcopter does not hit anyone during take-off or landing
6. Children must only operate the quadcopter when supervised by an adult. The quadcopter must be kept within the pilot's (and supervisor's) field of view in order to keep the quadcopter under control.
7. Do not charge disposable batteries. Pay attention to the polarity when inserting or replacing batteries and do not mix old and new batteries or batteries of different types
8. Turn off the remote control and quadcopter when you are not using the product and remove the batteries in the remote control.
9. Do not short circuit any batteries.

# CARE AND MAINTENANCE

1. Regularly clean the product using a clean cloth.
2. Avoid exposing the product to direct sunlight or high temperatures.
3. Do not place the product in water as this will damage the electrical components.
4. Regularly inspect the charging plug and other parts for damage. If there are any signs of damage, discontinue use immediately until the product has been fully repaired.

# CONTENTS

**Product packaging includes these items as follows:**

- Quadcopter
- Transmitter
- Propellers
- Screws(4pcs)
- Screwdriver
- Camera
- Covers
- Memory card
- Card reader
- Instruction manual
- Clips, use for phone ( X54HW )
- USB Charging Cable

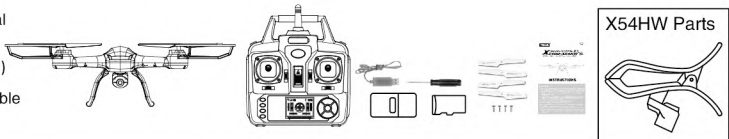

# REMOTE CONTROL

**Overview of remote control buttons**

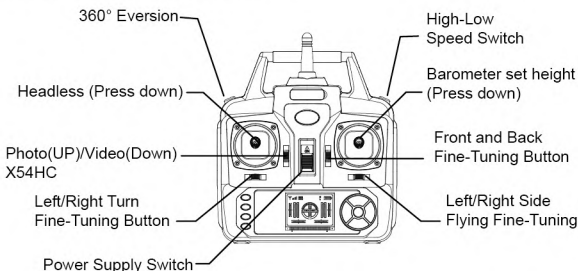

## Battery installation for remote control:

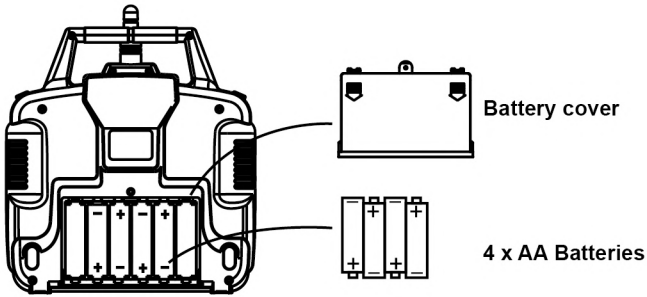

1. Battery Installation Method: Open up the battery cover at the back of the remote control. Correctly place 4 x AA alkaline batteries in the battery box in strict adherence to the polarity instructions (the batteries are optional).



1. During the battery installation, it must be ensured that the polarities of the batteries are matched with that of the battery box. No battery shall be installed with the opposite polarity.
2. Please do not use new and old batteries together.
3. Please do not use different types of batteries together.

## Remote control button and lcd display functions description

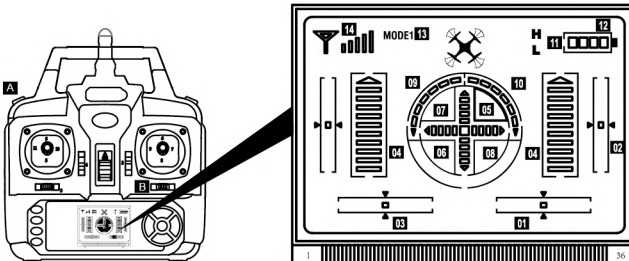

1. **Fine-tuning of left and right side flying:** After switching on the remote control, it is displayed at the middle point.
2. **Fine-tuning of forward and back:** After switching on the remote control, it is displayed at the middle point.
3. **Fine-tuning of left and right turning:** After switching on the remote control, it is displayed at the middle point.
4. **Accelerator Display:** After frequency-matching, it is displayed at the middle point.
5. **Forward Display:** When the right joystick is pushed forward, it will be gradually ascended; the forward speed of the aircraft will be gradually increased.
6. **Backward Display:** When the right joystick is pushed backward, it will be gradually ascended; the backward speed of the aircraft will be gradually increased.
7. **Left Side Flying Display:** When the right joystick is pushed to the left, it will be gradually ascended; the left side flying speed of the aircraft will be gradually increased.
8. **Right Side Flying Display:** When the right joystick is pushed to the right, it will be gradually ascended; the right side flying speed of the aircraft will be gradually increased.
9. **Left Turning Display:** When the left joystick is pushed to the left, it will be gradually ascended; the left turning speed of the aircraft will be gradually increased.
10. **Right Turning Display:** When the left joystick is pushed to the right, it will be gradually ascended; the right turning speed of the aircraft will be gradually increased.
11. **Fast-Slow Gear Display:** Press against Button A can enable the aircraft to execute the toggle of fast-slow gear. The fast gear is H, while the slow gear is L.
12. **Power Supply Display:** Display the current power capacity of the remote control.
13. **Mode Display:** The default is MODE1 upon starting up. Push the Button B to the right and switch on the power supply switch at the same time can toggle to MODE2.
14. **Signal Display:** Display the strong and weak signals.

# PREPARATION FOR FLIGHT

## I. Flight preparation

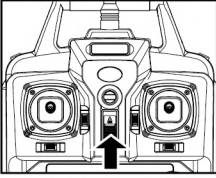

Step 1: Open up the power supply switch of the remote control.

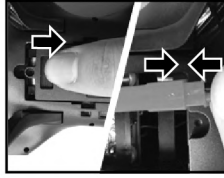

Step 2: Open the battery cover and insert the battery into power port.

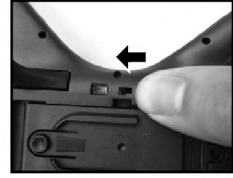

Step 3: Move the on/off button on the bottom of the quadcopter to the ON position to turn the quadcopter on.

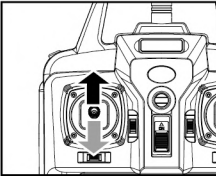

Step 4: Push the left lever (accelerator) to the highest point and then reset to the lowest point. When the indicator lights in the aircraft change from quick flashing to the continuous lighting, it means that the aircraft goes into the flight standby mode.

## II. Switching on the aircraft

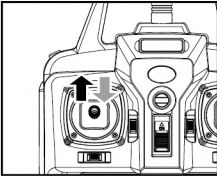

Method 1: push the left lever (accelerator) to the highest point and then reset to the center, the ventilation blade of aircraft starts rotating slowly.

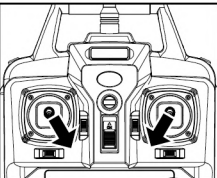

Method 2: Move the left and right joysticks inwards in an internal loop of "8" for 1 second, the ventilation blade of aircraft starts rotating slowly.

## III. Switching off the aircraft

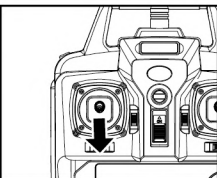

Method 1: Push the left joystick (Accelerator) to the lowest level and stay there for 2 to 3 seconds, the aircraft can then be switched off.

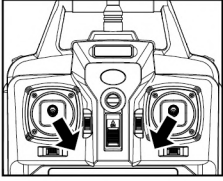

Method 2: Move the left and right joysticks inwards in an internal loop of "8" for 1 second, and the aircraft can be switched off.

## CHANGE BATTERY OF QUADCOPTER

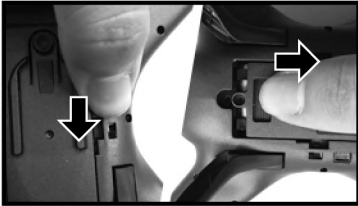

1. Push the on/off switch of quadcopter to OFF position then open the battery cover.

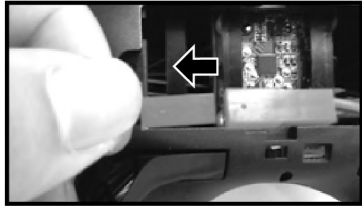

2. Pull out the battery wire from the power port.

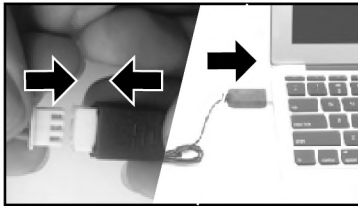

3. Connect the USB plug to your computer, then connect the battery cable to the USB connector (the LED indicator stays off when charging and turns on when charging is complete).

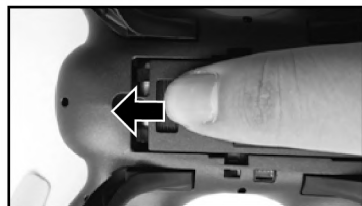

4. Reconnect the battery wire to power port, close the battery cover.

Charging the quadcopter for 80 minutes will provide at least 6 minutes of flight time. The quadcopter can fly to a distance of up to 50 m when flown outside with the remote control. When controlled via Wi-Fi, the device can fly to a distance of 20 m when controlled using an Apple device and 30 m for an Android device.

### Pay attention to the following when charging the battery:

Never expose the charged battery to high temperatures such as naked flames or electric heaters, as this may damage the battery or cause an explosion.

Never use the battery to hit or strike the surface of hard objects.

Never place the battery in water and ensure that it is stored in a dry place.

Never dismantle the battery.

Never leave the battery unattended whilst charging.

## INSTALL LANDING SKIDS & PROPELLOR PROTECTING FRAME

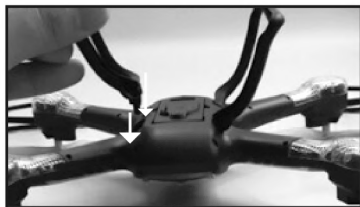

1. Install the landing skids to the bottom of quadcopter .

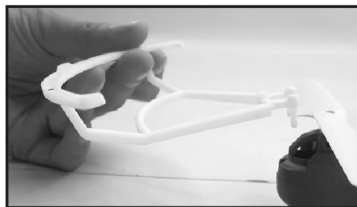

2. Install the propellor guard to every corner and lock screws .

## Flight Controls

### Ascending and descending control

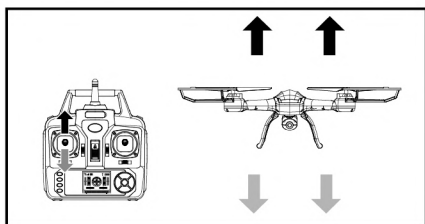

When the left joystick (Accelerator) is pushed upwards or downwards, the aircraft will ascend or descend correspondingly.

### Forward and backward control

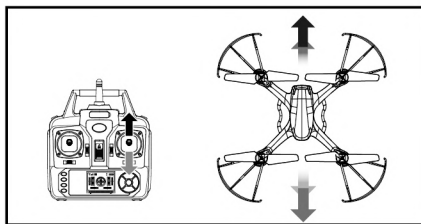

When the right joystick (Turning Rudder) is pushed upwards or downwards, the aircraft will advance forward or backward correspondingly.

### Left turning and right turning control

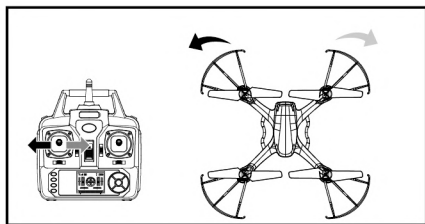

When the left joystick (Accelerator) is pushed towards the left or right, the aircraft will turn left or right correspondingly.

### Left side flying and right side flying control

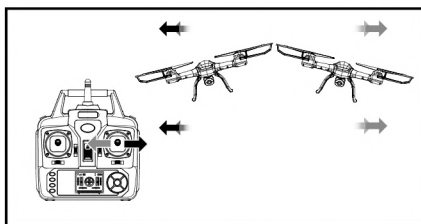

When the right joystick (Turning Rudder) is pushed towards the left or right, the aircraft will fly sideward on the left or right correspondingly.

## Fine-tuning operation

### Forward and backward fine-tuning control

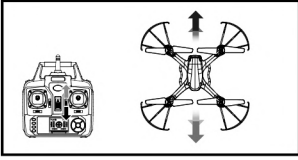

When the aircraft is hovering in the air, in the event that the aircraft is automatically advancing forward or backward, it can be rectified by pressing downwards or upwards the fine-tuning button correspondingly.

### Left/right side flying fine-tuning control

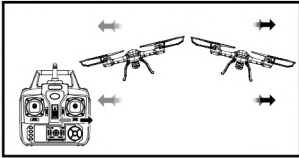

When the aircraft is hovering in the air, in the event that the aircraft is automatically flying sideward on the left or right, it can be rectified by pressing right or left on the fine-tuning button correspondingly.

### Left/right side turning fine-tuning control

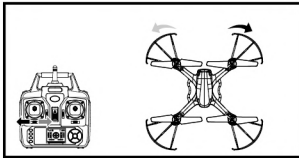

When the aircraft is hovering in the air, in the event that the aircraft is automatically turning left or right, it can be rectified by pressing right or left on the fine-tuning button correspondingly.

## PRODUCT FEATURES

### I. Low-voltage protection:

When the four indicator lights at the bottom of aircraft start flicking, it means that the aircraft's battery power is low. At this time, the aircraft will initiate the height-limiting function and will drop to certain safety height.

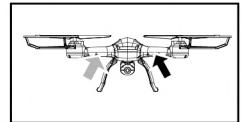

### II. Overcurrent protection:

When the aircraft encounters direct impact from foreign object or is stuck under the circumstances in which its blades are rotating, the electric circuit of the aircraft will enter into the overcurrent protection mode.

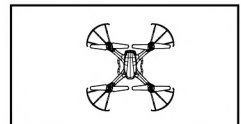



### III. Level calibration function:

Place the aircraft on a levelling surface and at the same time, push both left and right joysticks to the lower right corners and stay there for 2 to 3 seconds; the normal light indicator on the aircraft will blink rapidly, and it will return back to the normal status after about 2 to 3 seconds. The level calibration is successful.

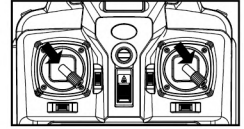

### IV. 3D overturning function:

When you are familiar with the basic actions, you can proceed to explore even more exciting and risky overturning actions. Fly the aircraft to a height of above 5 m from the ground, press against the upper right corner button (Overturning Button) on the remote control and simultaneously push the right joystick to the highest level of Front/Back/Left/Right, the aircraft will now be executing the Front/Back/Left/Right overturning function.

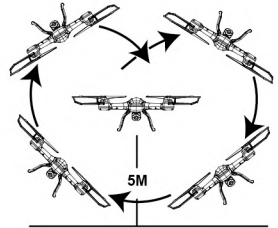

**Note: When the batteries are fully charged, it will have the best overturning effect.**

### V. Pressure hovering height adjustment function:

After using the left joystick (Accelerator) to control the ascending / descending flight of the aircraft, free up the left joystick (Accelerator) and the aircraft will still hover at that height when the joystick is free.

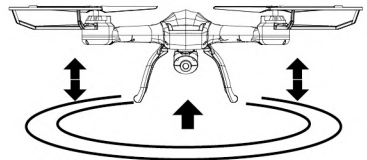

### VI. Headless function:

#### 1. Defining forward direction:

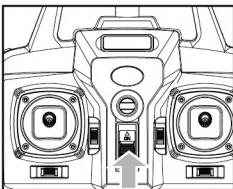

1. Open up the power supply switch of the remote control.

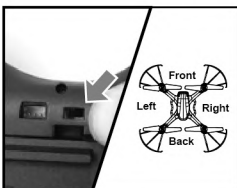

2. After connecting the aircraft to the power supply, push the switch to "NO" location, and adjust the specified direction of the aircraft's head under the headless mode as the new forward direction.

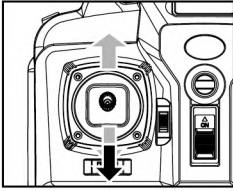

3. Push the accelerator joystick of the remote control to the highest level and then, pull back into the lowest level. When the remote control issues a long beep sound, it means the frequency and defining forward direction functions are completed.

## 2. Toggling between headless function and normal function:

1. When the aircraft has completed its matching of frequency, the default of the aircraft is normal mode. At this time, the light indicator on the aircraft is in the long blinking mode. When pressing and holding on to the left upper corner of the headless function toggle button for 2 seconds, the remote control will issue a "Di, Di, Di, ... .." sound indicating it has entered into the headless mode. In subsequent long pressing on the same button for 2 seconds, upon hearing a long "Di" sound, the aircraft has exited from the headless mode. In the headless mode, the four lights on the aircraft is slowly blinking. Every blink is within 4 seconds)

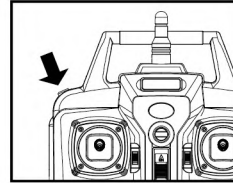

2. Under the headless mode, the operator does not require to differentiate the head position of the aircraft, and he just needs to control the aircraft using the joystick's direction of the remote control.

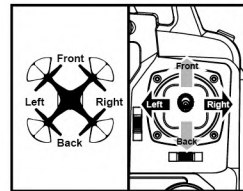

## 3. Rectification for the defining forward direction function:

1. When the aircraft encounters a direct impact with foreign objects in the headless mode, if there is an occurrence of deviation of the defined direction, it is only required to push the accelerator and the direction joystick to the left bottom corners simultaneously after rectifying the flying direction of the aircraft in the correction direction. When the light indicator of the aircraft is in a long "ON" mode after slowly blinking for 3 seconds, it indicates the rectification is complete.

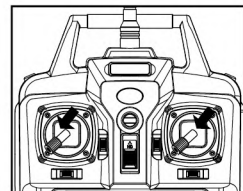

## AERIAL PHOTO-TAKING FUNCTION(X54HC)

### 1. Method:

- A. Insert the plug connector of the camera into the specified aircraft's socket.
- B. Open up the power supply of the aircraft. When the red light on the camera has turned green, it means the camera is in a normal operating mode. When the red light has turned off after lighting up and the green light is off, it means the SD card is not connected to the camera.

## 2. Description of photo-taking and video recording functions:

**Photo-taking Function:** When the camera is in the normal operating mode, press the “Photo-taking/Video Recording Button” upwards and the remote control will issue a beep sound. When the photo-taking is completed, the red light indicator on the camera and the LED light on the aircraft will blink once.

**Video Recording Function:** When the camera is in the normal operating mode, press the “Photo-taking/Video Recording Button” downwards and the remote control will issue two beep sounds. When the red light indicator on the camera and the LED light on the aircraft blink continuously, it means the video recording is in operation.

Pressing the button again will result in the red light turning green, indicating the video recording has just ended.

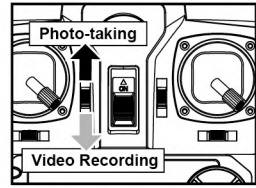

## WI-FI FEATURES (X54HW)

### 1. Download the installation software:

For Android mobile phones, please kindly (visit [www.symatoys.net](http://www.symatoys.net)) or scan the QR code to download the SYMA FPV installation software.

For Apple mobile phones, please kindly proceed to APP STORE to download the SYMA FPV installation software or scan the QR code to download the SYMA FPV installation software.

Warm reminder: Two-dimension code is provided in color box packing and back cover of specification to scan. Please concern official website APP STORE of SYMA or the latest reminder of Google play to acquire the latest SYMA FPV.

### 2. Connection description:

Connect model power supply. The FPV light indicator is green and will become red blinking light after approximately 20 seconds, awaiting the connection for mobile phone. At this moment, click on “Settings” option in mobile phone and activate WIFI. In the WIFI's search column, look for “FPV WIFI \*\*\*\*” connection, and click on connection until the message “has been connected” is shown, which indicates that the connection is successful. Now, exit the “Settings” option. Open up the SYMA FPV software, and click the “START” icon to enter into the control panel. The mobile phone screen has entered into the real-time imaging scenarios. The full bar of the WIFI's signal indicates that the current signal is at its strongest.



1. Open up SYMA FPV software.



2. Click on “START” icon.



3. The mobile phone screen is displays with real-time imaging scenarios.

### 3. Real-time transmission gui icon description

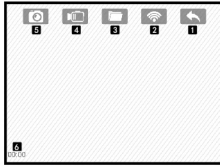

1. Back
2. WIFI's Signal
3. Checking of Photos and Videos
4. Video Recording
5. Photo-Taking
6. Video Recording Time Display

### 4. Real-time transmission aerial photo-taking

Photo-Taking and Video Recording: When the WIFI camera is operating in normal conditions, please click on the photo or video icon on the real-time transmission GUI, and immediately you can conduct photo-taking or video recording. (The completed files for photo-taking or video recording can be found in the "Checking of Photos and Videos" files.)

Note: When activating the mobile phone software to conduct real-time transmission operating mode, the flight distance of the aircraft will be shortened by half !

### 5. Memory card storage function.

This 720P WIFI camera has the function of memory card storage. When 720P WIFI camera has the memory card, mobile phone and memory card will store pictures/videos simultaneously. When 720P WIFI camera has no memory card, pictures/cards are only stored in a mobile phone.

## RECTIFICATION PROCEDURES

Problem	Reason	Solution
The aircraft has no response	<ol style="list-style-type: none"> <li>1. The aircraft has entered into lowvoltage protection.</li> <li>2. When the power of the remote control is weak, the power light indicator will blink.</li> <li>3. The channel selection of the remote control does not match with the aircraft's coding.</li> </ol>	<ol style="list-style-type: none"> <li>1. Charge up the aircraft.</li> <li>2. Change the batteries of the remote control.</li> <li>3. Adjust the channel of both the remote control and aircraft such that they are in synchronized mode.</li> </ol>
The flight response of the aircraft is not sensitive	<ol style="list-style-type: none"> <li>1. The power of the remote control is weak.</li> <li>2. There is an interference with the same frequency as that of the remote control.</li> </ol>	<ol style="list-style-type: none"> <li>1. Change the batteries.</li> <li>2. Change to a place where there is no interference with the same frequency.</li> </ol>

Problem	Reason	Solution
The aircraft is flying towards its side in one direction during hovering	1. The aircraft is not calibrated level to the ground.	1. Re-adjust the calibration until the aircraft is level to the ground. For further details, please refer to Point III of Page 8 (Level Calibration Function).
In the headless state, it is biased towards the front direction	1. Many collisions may cause head biasness.	1. Re-define the front direction. For further details, please kindly refer to Point VI of Page 8 and 9 (Headless Function).

## X54HC ACCESSORIES (OPTIONAL)

You can choose your favourite optional accessories as below. In order to make it easier for the customers to choose and purchase, we have specially offered each and every accessory. The accessories can be purchased through the local distributors. Please kindly specify the colours during your purchase.



X54HC-1  
Upper body



X54HC-2  
Lower body



X54HC-3  
Rotating blades



X54HC-4  
Protective gear



X54HC-5  
Landing skids



X54HC-6  
Motor holder



X54HC-7  
Lampshades

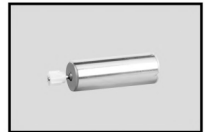

X54HC-8  
Motor A



X54HC-9  
Motor B



X54HC-10  
Light boards

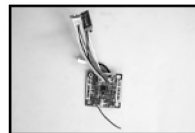

X54HC-11  
Receiver board



X54HC-12  
Battery



X54HC-13  
USB



X54HC-14  
Camera



X54HC-15  
Remote control

## X54HW ACCESSORIES (OPTIONAL)

You can choose your favourite optional accessories as below. In order to make it easier for the customers to choose and purchase, we have specially offered each and every accessory. The accessories can be purchased through the local distributors. Please kindly specify the colours during your purchase.



X54HW-1  
Upper body



X54HW-2  
Lower body

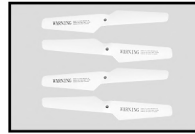

X54HW-3  
Rotating blades



X54HW-4  
Protective gear



X54HW-5  
Landing skids



X54HW-6  
Motor holder



X54HW-7  
Lampshades

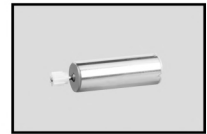

X54HW-8  
Motor A



X54HW-9  
Motor B



X54HW-10  
Light boards

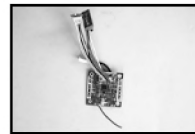

X54HW-11  
Receiver board



X54HW-12  
Battery



X54HW-13  
USB



X54HW-14  
Camera



X54HW-15  
Remote control



X54HW-16  
Mobile phone fixed  
mounting

# MAIN SPECIFICATIONS

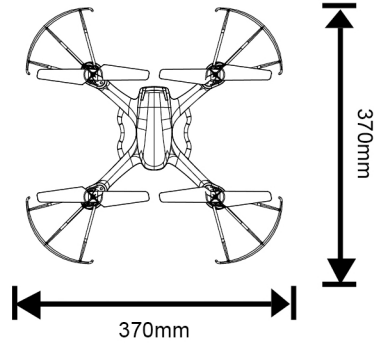
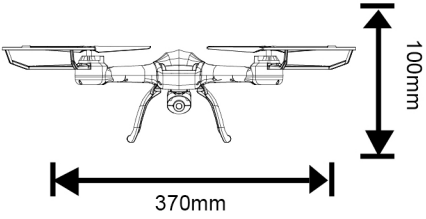

**Aircraft's Length:370mm    Aircraft's Width:370mm**  
**Aircraft's Height:100mm    Motor's Model: Ø8**  
**Battery: 3.7V/600mAh lithium battery**



SPECIFICATIONS AND COLORS OF CONTENTS MAY VARY FROM PHOTO.



Two-dimension code  
of Android system



Two-dimension code  
of iPhone iOS system

**The company has the right of final interpretation  
of this instruction manual statement.**